

Please Approve this Drawing	
Date	
Signature	

NO.	Part Name	Q'TY	Material	Plated surface
1	Plunger	1	不锈钢	N/A
2	Barrel	1	不锈钢	N/A
3	档圈	1	不锈钢	N/A
4	Spring	1	SUS304	N/A

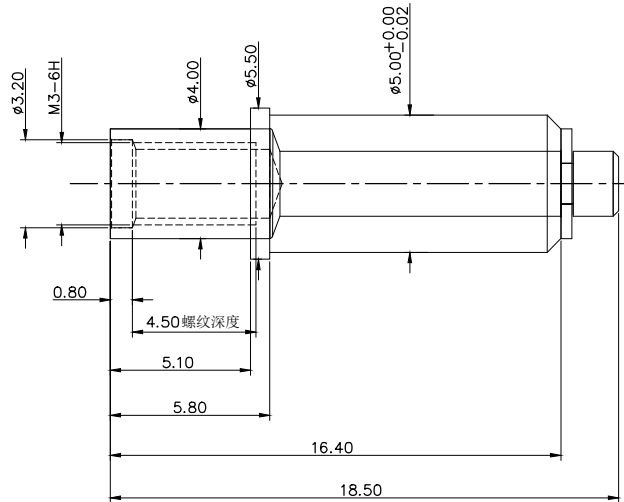

NOTES:

- Mechanical
 - .Full store: 5.00 mm
 - .Working Store: 5.00 mm
 - .Spring Force: 10±1N at Normal Working Height
 - .Durability:100,000 cycles(minimum)
- Environmental
 - .Operating Temperature: -25°C~+85°C
 - .Humidity Range: 10%RH~90%RH
 - .Salt Spray: 48 Hours
- Part To Be Free Form Manufacturing Lubricants.
- To ensure the best usage,please operate it based on the working height.

DRAWN	tony	DATE	2020.03.09			东莞市燊瑞电子科技有限公司				
CHECKED		SCALE	10:1	VER.	B.0					
APPROVED		TITLE	Pogo pin			Ang:	Dim:			
PROJECT		DRAWING NO.	C1651-01			0 ±1°	0 ±0.15			
SHEET	1 of 1	UNIT	mm			.0 ±0.5°	.0 ±0.10			
						.00 ±0.25°	.00 ±0.05			